

# Recent Progress on the KMOS Multi-object Integral Field Spectrometer

Ray Sharples<sup>1</sup>  
 Ralf Bender<sup>2, 4</sup>  
 Alex Agudo Berbel<sup>4</sup>  
 Richard Bennett<sup>3</sup>  
 Naidu Bezawada<sup>3</sup>  
 Nicolas Bouché<sup>4</sup>  
 David Bramall<sup>1</sup>  
 Mark Casali<sup>6</sup>  
 Michele Cirasuolo<sup>3</sup>  
 Paul Clark<sup>1</sup>  
 Mark Cliffe<sup>3</sup>  
 Richard Davies<sup>4</sup>  
 Roger Davies<sup>5</sup>  
 Niv Drory<sup>4</sup>  
 Marc Dubbeldam<sup>1</sup>  
 Alasdair Fairley<sup>3</sup>  
 Gert Finger<sup>6</sup>  
 Reinhard Genzel<sup>4</sup>  
 Reinhold Haefner<sup>2</sup>  
 Achim Hess<sup>2</sup>  
 Paul Jeffers<sup>3</sup>  
 Ian Lewis<sup>5</sup>  
 David Montgomery<sup>3</sup>  
 John Murray<sup>3</sup>  
 Bernard Muschielok<sup>2</sup>  
 Natascha Förster Schreiber<sup>4</sup>  
 Jeff Pirard<sup>6</sup>  
 Suzie Ramsey-Howat<sup>6</sup>  
 Phil Rees<sup>3</sup>  
 Josef Richter<sup>2</sup>  
 David Robertson<sup>1</sup>  
 Ian Robson<sup>3</sup>  
 Stephen Rolt<sup>1</sup>  
 Roberto Saglia<sup>2</sup>  
 Joerg Schlichter<sup>2</sup>  
 Matthias Tecza<sup>5</sup>  
 Stephen Todd<sup>3</sup>  
 Michael Wegner<sup>2</sup>  
 Erich Wozzorek<sup>4</sup>

The instrument is being built by a consortium of UK and German institutes working in partnership with ESO and is now in the manufacture, integration and test phase. In this article we describe recent progress with the design and construction of KMOS and present the first results from the subsystem test and integration.

KMOS is one of a suite of second generation instruments which, along with HAWK-I (Kissler-Patig et al., 2008), X-shooter (Vernet et al., 2009), MUSE (Bacon et al., 2006) and SPHERE (Beuzit et al., 2006), will revolutionise the observing capabilities of the Paranal Observatory in the next decade. KMOS is a unique design of near-infrared multi-object spectrograph that uses deployable integral field units (d-IFUs) to obtain spatially resolved spectra for multiple target objects selected from within an extended field of view. d-IFUs have a significant advantage over multi-slit spectrographs because of the reduced slit contention in crowded fields and their insensitivity to slit losses due to extended galaxy morphology and orientation. KMOS will be mounted onto the Nasmyth platform of the Very Large Telescope (VLT) Unit Telescope 1 (UT1) and will use the Nasmyth acquisition and guidance (A&G) facilities. The top-level scientific requirements are: (i) to support spatially resolved (3D) spectroscopy; (ii) to allow multiplexed spectroscopic observations; (iii) to allow observations across the  $I$ ,  $Z$ ,  $Y$ ,  $J$ ,  $H$ , and  $K$  infrared atmospheric windows

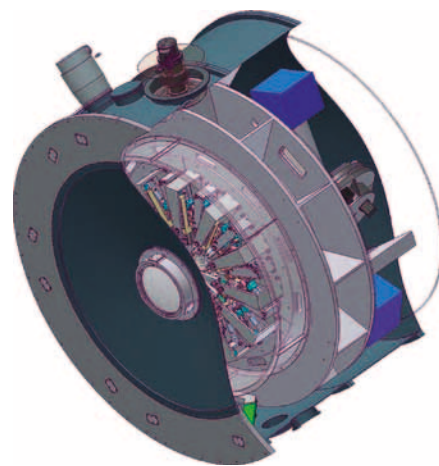

Figure 1. Cutaway drawing of the main KMOS cryostat design showing the entrance window followed by the pickoff arm module layer, the integral field unit module layer and the spectrograph module layer. Each 1/3 sector contains 8 robotic arms, 8 IFUs and 1 spectrograph to allow a sequential approach to assembly, integration and test, and easier maintenance.

from 0.8 to 2.5  $\mu\text{m}$ . These requirements have been flowed-down during a series of ever more detailed design reviews to arrive at the final design specification (Table 1). KMOS completed its Final Design Review in April 2008 and is now in the manufacture, integration and test phase. Key milestones are listed Table 2.

The final design employs 24 robotic arms that position fold mirrors at user-specified locations in a 7.2-arcminute diameter field of view (Bennett et al., 2008). Each arm selects a subfield on the sky of  $2.8 \times 2.8$  arcseconds. The size of the

<sup>1</sup> Department of Physics, University of Durham, United Kingdom

<sup>2</sup> Universitätssternwarte München, Germany

<sup>3</sup> United Kingdom Astronomy Technology Centre, Royal Observatory, Edinburgh, United Kingdom

<sup>4</sup> Max-Planck-Institut für extraterrestrische Physik, Garching, Germany

<sup>5</sup> Sub-Department of Astrophysics, University of Oxford, United Kingdom

<sup>6</sup> ESO

Table 1. Design specifications for the KMOS spectrograph.

Parameter	Final Design
Instrument total throughput (mean)	$I$ > 20%, $Y$ > 20%, $H$ > 30%, $K$ > 30%
Wavelength coverage	0.8 to 2.5 $\mu\text{m}$
Spectral resolution	$R = 3300, 3400, 3800, 3800$ ( $I$ , $Y$ , $J$ , $H$ , $K$ )
Number of IFUs	24
Extent of each IFU	$2.8 \times 2.8$ arcseconds
Spatial sampling	$0.2 \times 0.2$ arcseconds
Patrol field	7.2-arcminute diameter circle
Close packing of IFUs	> 3 within 1 sq. arcminute
Closest approach of IFUs	Edge-to-edge separation of > 6 arcseconds

Table 2. Key KMOS milestones.

Milestone	Date
Preliminary Design Review Closeout (PDR)	May 2006
Final Design Review Closeout (FDR)	April 2008
Preliminary Acceptance Europe (PAE)	(February 2011)

KMOS is a near-infrared multi-object integral field spectrometer that is one of a suite of second generation instruments under construction for the VLT.

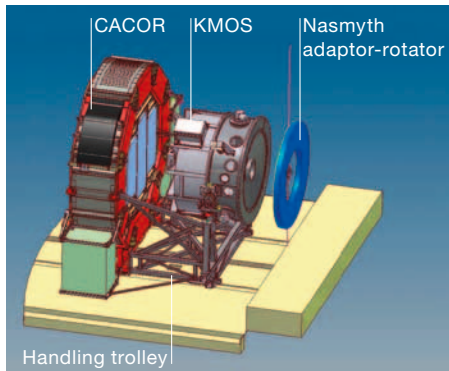

Figure 2 (left). KMOS layout on the Nasmyth platform showing the locations of the main cryostat and the CACOR cable rotator.



Figure 3 (right). The KMOS main cryostat undergoing its first cooldown cycles. The closed-cycle coolers are visible around the base of the cryostat; the remaining ports contain the feedthroughs for some of the 1500 electrical connections into the cryostat. The electronics rack to the right contains all the housekeeping electronics and will eventually be mounted on the Nasmyth platform.

subfields is tailored specifically to the compact sizes of high redshift galaxies, with a spatial sampling (0.2 arcseconds per pixel) designed to sample the excellent infrared seeing at Paranal ( $FWHM_{median} = 0.52$  arcseconds in the  $K$ -band). The subfields are then anamorphically magnified onto 24 advanced image slicer IFUs that partition each subfield into 14 slices, with 14 spatial pixels along each slice (Dubbeldam et al., 2006). Light from the IFUs is dispersed by three cryogenic grating spectrometers that generate  $14 \times 14$  spectra, each with  $\sim 1000$  Nyquist-sampled spectral resolution elements, for all of the 24 independent subfields (Tecza et al., 2006). The spectrometers each employ a single  $2k \times 2k$  Hawaii-2RG HgCdTe detector. The optical layout for the whole system has a threefold symmetry about the Nasmyth optical axis, allowing a staged modular approach to assembly, integration and test (Figure 1).

In the following sections we present the progress on the individual subsystem components within KMOS and note where design changes have been implemented compared to our original concept (Sharples et al., 2005).

### Cryostat and CACOR

The KMOS cryostat is the main support structure for the optomechanical components that make up the instrument and mounts directly onto the Nasmyth rotator. It uses three low-vibration Leybold 10MD cryocoolers to maintain an internal optical bench at a temperature below  $T = 140$  K, in order to minimise the thermal background radiation and to keep the de-

tor at a temperature below  $T = 80$  K to minimise dark current and persistence. A major design change after the preliminary design review has been to remove the electronics racks and services from the outside of the cryostat and to mount these on a co-rotating structure (CACOR) located separately on the Nasmyth platform (Figure 2) in order to provide an improved mass margin with respect to the telescope Nasmyth rotator/adaptor limit (3000 kg). The cryostat is a hybrid aluminium–steel vessel with a diameter of 2 metres. Figure 3 shows the cryostat undergoing its first cooldown in September 2009. The performance is now excellent with plenty of cooling power in reserve and a hold-time of more than three months (without pumping).

### Pickoff arms

One of the more unusual elements in KMOS is the pickoff module that relays the light from the 24 selected regions distributed within the patrol field to an intermediate focus position at the entrance to the integral field unit module. The robotic pickoff arms are of an  $(r, \theta)$  design (Figure 4) with pivot points located

in a circle around the periphery of the patrol field and are driven in radial and angular motions by two cryogenically prepared stepper motors.

The arms are arranged into two layers on either side of the Nasmyth focal plane to improve the access to target objects in crowded fields, whilst avoiding interference between neighbouring arms. This focal plane is flat and telecentric thanks to a pair of all-silica field lenses, one of which forms the entrance window to the cryostat. The pickoff arm design has been through a number of refinements based on repeatability, flexure and lifetime tests conducted in a relevant environment (i.e. in vacuum at  $T \sim 140$  K). Whilst the positioning of the arms is open-loop via step-counting from datum switches, there is a linear variable differential transformer (LVDT) encoder on each arm that is used to check for successful movement. In addition a hardware collision detection system is also implemented as a third level of protection which can sense if any two arms have come into contact and stop the movement of arms within  $10 \mu\text{m}$ . The absolute positioning accuracy of the arm when cold has been measured using an automated

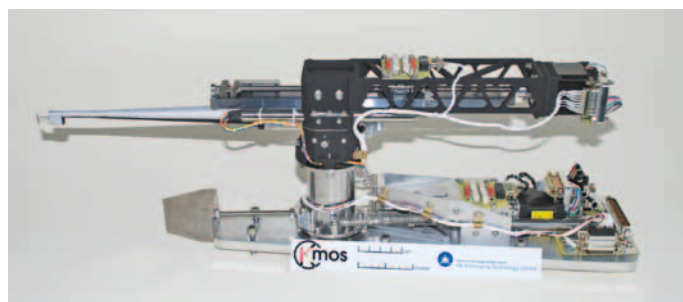

Figure 4. One of the fully assembled KMOS pickoff arms. The linear motion is a stepper motor drive in the top of the arm, and the angular motion is a stepper drive in the base. The total length of the mechanism is  $\sim 50$  cm.

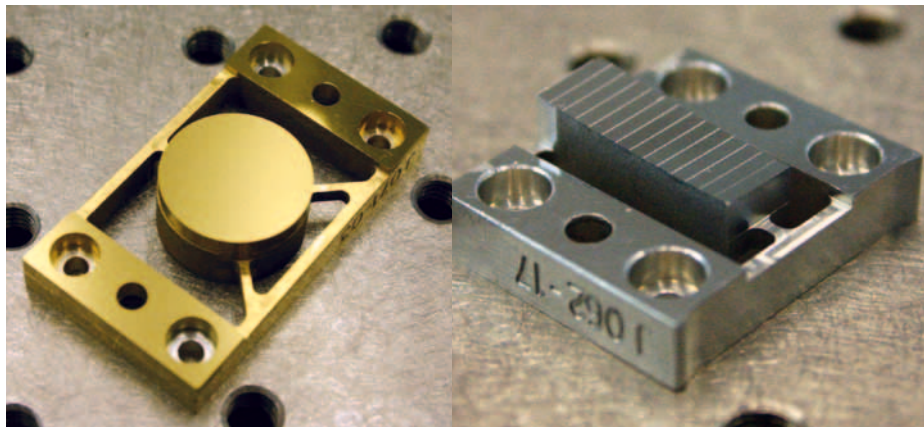

Figure 5. Two of the diamond-machined optical parts from the IFU assembly. On the left is a gold-coated K-mirror (an off-axis parabola) and on the right is an uncoated image slicer array with the 14 slices visible.

laser tracker system and is  $< 50 \mu\text{m}$  (0.1 arcseconds).

The pickoff module also contains the instrument calibration unit (tungsten, argon and neon sources) and an order-sorting filter wheel that provides focus compensation between the different bands. The cold-stop for each channel is at the base of the arm, after which an intermediate image is formed by a fixed K-mirror assembly that orientates the pick-off fields so that their edges are parallel on the sky. This enables a sparse matrix configuration for the arms where the KMOS IFUs can be used to map a contiguous region of sky covering  $65 \times 43$  ( $33 \times 16$ ) arcseconds in 16 (9) dither pointings.

### Integral field units

The IFU subsystem contains optics that collect the output beams from each of the 24 pickoffs and reimages them with appropriate anamorphic magnification onto the 24 image slicers. The anamorphic magnification is required in order that the spatial sampling pixels (“spaxels”) on the sky are square whilst maintaining Nyquist sampling of the spectra on the detector in the spectral dimension. The slices from groups of eight subfields are aligned and reformatted into a single 254-mm long slit at the entrance to the three spectrometers. The optics in a single IFU comprises: two off-axis aspheric re-imaging mirrors; a third re-imaging mir-

ror defined with a more complex geometry using Zernike polynomials; one monolithic slicing mirror array containing 14 slices with spherical surfaces in different orientations; two monolithic pupil mirror arrays containing seven facets, each with spherical surfaces; and one monolithic slit mirror array containing 14 facets with toroidal surface form. All of the micro-optics in the IFUs are produced by diamond-machining using a combination of diamond-turning and raster fly-cutting techniques. This technique allows arrays of multi-faceted components to be manufactured with in-built mounting surfaces, all to sub-micron accuracy. Particular attention was paid to minimising the micro-roughness on the optical surfaces, which was in the range 5–10 nm root mean square (rms) for many components. Detailed metrology measurements are being performed on every element to ensure that the stringent tolerances in form error and alignment for the IFUs have been achieved. Figure 5 shows some examples of the IFU components produced so far.

### Spectrographs

The three identical spectrographs each use a single off-axis toroidal mirror to collimate the incoming light, which is then dispersed via a reflection grating and refocused using a six-element transmissive achromatic camera onto a single

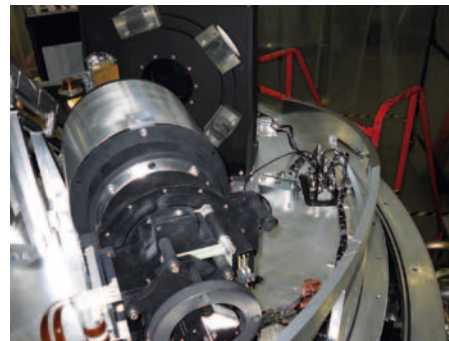

Figure 6. The first KMOS spectrograph mounted on its baseplate. The camera barrel is in the middle distance, with the detector focus mount in the foreground, and the grating turret with dummy gratings at the back.

Hawaii-2RG infrared detector. The gratings are mounted on a five-position wheel which allows optimised gratings to be used for the individual bands together with a single lower resolution grating covering two atmospheric bands ( $H+K$ ). Following a decision early in the project to extend the wavelength of operation below  $1 \mu\text{m}$ , where the detector still has excellent quantum efficiency, a series of optimised order-sorting filters have been procured as shown in Table 3. After initial cold performance tests at Oxford University, the first spectrograph has now been integrated into the main cryostat to begin full system tests (Figure 6).

### Control electronics and software

KMOS will be one of the most complex cryogenic instruments at the VLT with almost 60 degrees of freedom in the cryogenic mechanisms alone. Robust efficient software and reliable control electronics will be key to successful long-term operations and are being developed at the Universitäts-Sternwarte (USM) in Munich (Figure 7). In addition to instrument control software and housekeeping diagnostics, KMOS will have an optimised arm allocation tool, known as KARMA, which links directly to the ESO observation preparation software (P2PP). KARMA assigns arms to targets in a prioritised

Table 3. Spectrograph bandpasses.

Band	<i>I</i> Z	<i>Y</i> J	<i>H</i>	<i>K</i>	<i>HK</i>
$\lambda_{\text{start}}$ (nm)	800	1020	1450	1950	1500
$\lambda_{\text{end}}$ (nm)	1080	1345	1850	2500	2380
Spectral resolution	3327	3387	3840	3766	2052





Figure 7. An advanced prototype of one of the final electronics cabinets controlling four of the KMOS pickoff arms during tests at USM.

way, whilst ensuring that no invalid arm positions are selected and allows the user to manually reconfigure the list of allocated targets.

### Detectors

The KMOS detector system and electronics are being developed at ESO Garching and will use the latest generation of Hawaii-2RG detectors in combination with the new Next Generation Controller (NGC) readout system. The detectors will be fully substrate-removed to give excellent quantum efficiency ( $> 80\%$ ) across the whole 0.8 to 2.5  $\mu\text{m}$  region and have excellent performance (readout noise  $< 10\text{ e}^-$  rms on all four detectors for a single double-correlated sample (DCS) readout; dark current at  $T = 60\text{ K}$  is  $< 0.001\text{ e}^-/\text{sec}/\text{pixel}$ ). Each detector is adjusted manually for tip-tilt, but is mounted on a remotely operated focus stage (Figure 8).

### Data reduction pipeline

A customised data reduction pipeline is being provided for KMOS that will allow the observer to evaluate the data quality after each readout and apply sophisticated algorithms for coadding data cubes and subtraction of the sky background.

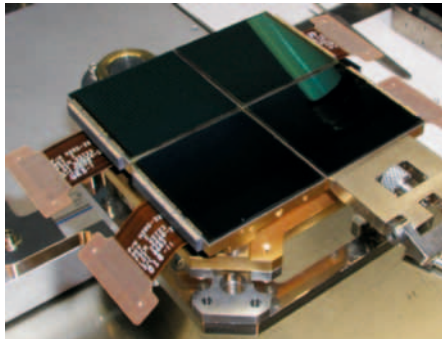
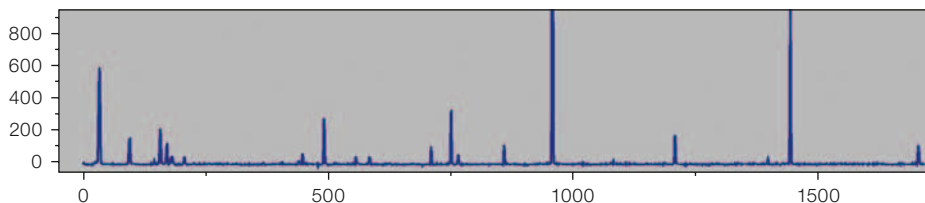
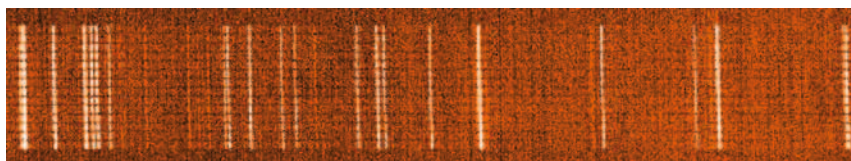

Figure 8. On the left the three KMOS science-grade detectors and one engineering-grade detector are shown mounted on a temporary four-chip mosaic mount for device characterisation at ESO. On the right are two of the three single-detector focus stages.



Figure 9 (below). The top image shows a subsection of the full Hawaii-2RG array containing a 2D argon arc  $H$ -band spectrum through one channel. In the spatial direction there are 14 separate slitlets (slices) visible. The lower image shows a 1D wavelength slice through this spectrum. The  $FWHM$  of the lines is  $\sim 2$  pixels. This is one of the first spectra taken with the full KMOS instrument with only initial adjustments for focus/tilt/alignment.



With over 4000 spectra per integration, automatic data processing and reduction methods will be essential to exploit fully the scientific potential of KMOS. The data reduction pipeline is being developed at the Max-Planck-Institut für extraterrestrische Physik (MPE) and will make use of the considerable experience and heritage available from the VLT SINFONI instrument.

### Current status

KMOS is currently undergoing the first stage of a sequential integration process at the UK Astronomy Technology Centre (ATC) in Edinburgh. The first step is to obtain an end-to-end qualification check of the complete cryogenic performance using a part-populated front segment with two complete channels comprising pick-

off arms, IFUs, spectrograph and detector system. Figure 9 shows the technical “first light” KMOS spectrum with the instrument cold, obtained using the instrument calibration unit on 20 January 2010. This significant milestone, which tests all the integrated subsystems, marks the first step towards Provisional Acceptance Europe, after which KMOS will be shipped to Paranal to begin telescope commissioning. We look forward to seeing the first exciting science from KMOS in 2011/12.

### References

- Bacon, R. et al. 2006, *The Messenger*, 124, 5
- Bennett, R. et al. 2008, *Proc. SPIE*, 7018, 73
- Beuzit, J.-L. et al. 2006, *The Messenger*, 125, 29
- Dubbeldam, M. et al. 2006, *Proc. SPIE*, 6273, 105
- Kissler-Patig, M. et al. 2008, *The Messenger*, 132, 7
- Sharples, R. et al. 2005, *The Messenger*, 122, 2
- Tecza, M. et al. 2006, *Proc. SPIE*, 6269, 141
- Vernet, J. et al. 2009, *The Messenger*, 138, 4