

Organisation at MPE

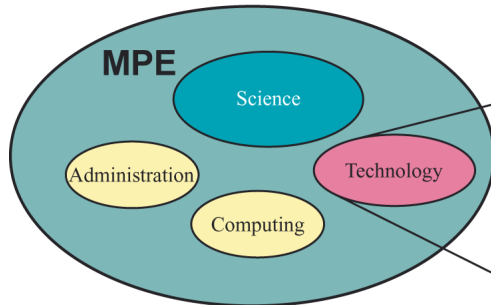

Organisation of technical groups at MPE

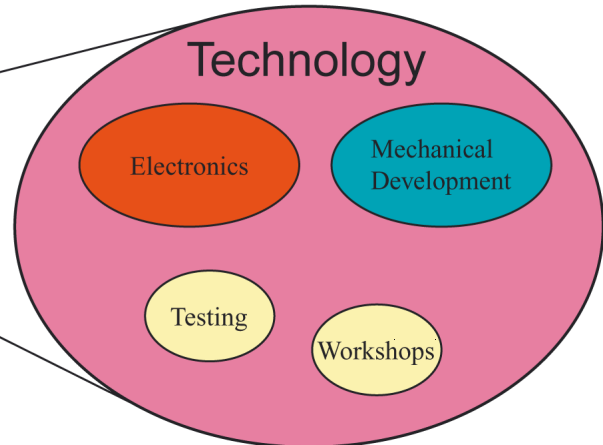

The technical groups are dedicated to innovation excellence and reliability for astrophysical experiments on ground and in space.

Science at the institute depends on instruments developed built and tested mostly by the technical groups of the institute, who are involved in big space borne projects like EPIC on XMM, PACS on Herschel, FIFI-LS on SOFIA, DUO-Camera on the NASA-SMEX-Mission DUO, PK 3+ and PK 4 for the ISS, GBM on GLAST and MEGA on a balloon and also in instruments for ground use like SPIFFI/SINFONI and PARSEC for the ESO VLT, LUCIFER for the LBT, the GROND Gamma-Ray-Burst experiment for La Silla from ESO and CAST at CERN.

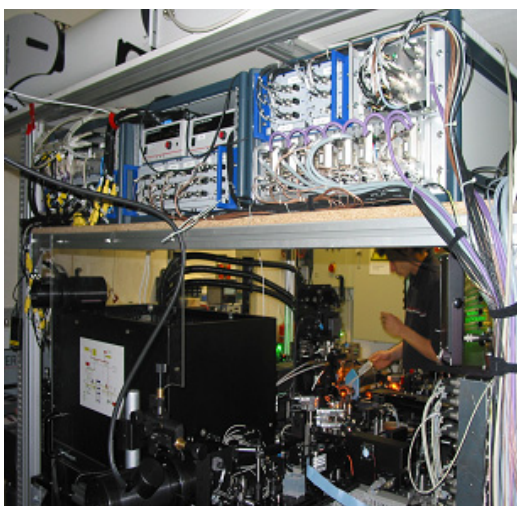

PARSEC Electronics

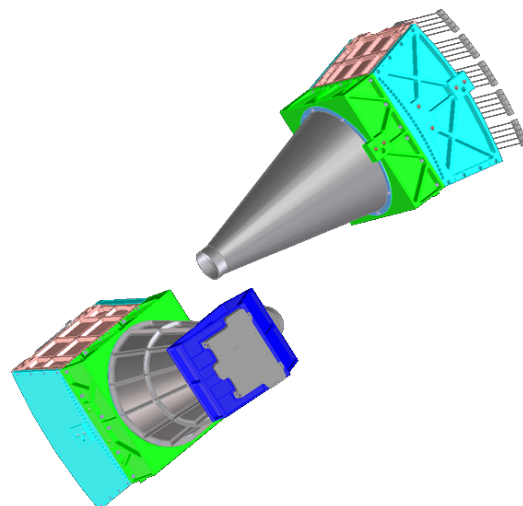

PACS Detectors